

DESIGN, FABRICATION AND EXPERIMENTAL TEST OF A HELICAL INDUCTION PUMP WITH ROTATING CORE

*L. Bühler**, *R. Stieglitz*

Karlsruhe Institute of Technology (KIT), P.O. Box 3640, 76021 Karlsruhe, Germany

**e-Mail: leo.buehler@kit.edu*

A design of a new type of liquid metal electromagnetic pump for medium flowrates and moderate pressure heads has been developed. The major difference compared to existing concepts is that the central iron core, which closes the magnetic flux lines, is fabricated from a single iron piece, which may freely rotate in order to avoid magnetization losses. The pump was designed and manufactured at KIT and tested in the liquid metal NaK loop of the MEKKA facility. Its performance curve (pressure head vs. flowrate) and efficiency have been determined for a variety of frequencies and magnitudes of applied 3-phase current.

Preface.

The present work results from a collaboration of both authors. We had the idea to design, manufacture and test a medium-scale liquid metal pump at reasonable costs. Although the work had been completed already several years ago, the results were never fully published, neither at a conference nor in a journal, despite the intention of doing so. Unfortunately, in December 2023 the second author, our dear friend and colleague Robert Stieglitz, unexpectedly passed away. Upon this sad circumstance, I remembered our collaboration on EM pumps and that it could be a good idea to publish the results now, in order to recall to the magnetohydrodynamics community Roberts unforgettable achievements in MHD and, in particular, the Karlsruhe geo-dynamo experiment [1, 2].

Introduction.

Introduction. Liquid metals, such as sodium Na, sodium-potassium NaK, lithium Li and lead-lithium PbLi, have been proposed as coolants in fast nuclear reactors or in blankets of future fusion reactors due to their high thermal conductance, their applicability at high temperature, and their favourable interaction with neutrons for fuel breeding purposes. For circulation of those electrically conducting fluids through circuits and heat exchangers on reactor scales, usually large annular linear induction pumps (ALIP) are the preferred choice at high flowrates [3]. Electromagnetic pumps have the advantage that they are hermetically tight with no penetration of a rotating axle. The latter could pose risks of potential leaking, which would represent a safety issue in case of alkali liquid metals or in nuclear applications. However, on medium scales ALIPs operate at quite poor efficiency, as shown, for instance, in [4], where the maximum efficiency was only about 5% or smaller.

For applications on a laboratory scale, permanent magnet rotor pumps became an interesting option for moderate flowrates and pressure heads due to their relative simple design [5, 6]. Higher pressure heads can be achieved by a helical design of the pump channels [6]. Instead of a rotating magnetic shaft as used in the latter references, it is possible to apply rotating magnetic fields created externally by 3-phase currents, as proposed, e.g., in [7] for pumping of liquid metals.

Based on the physical principles of helical induction pumps, we developed a design of

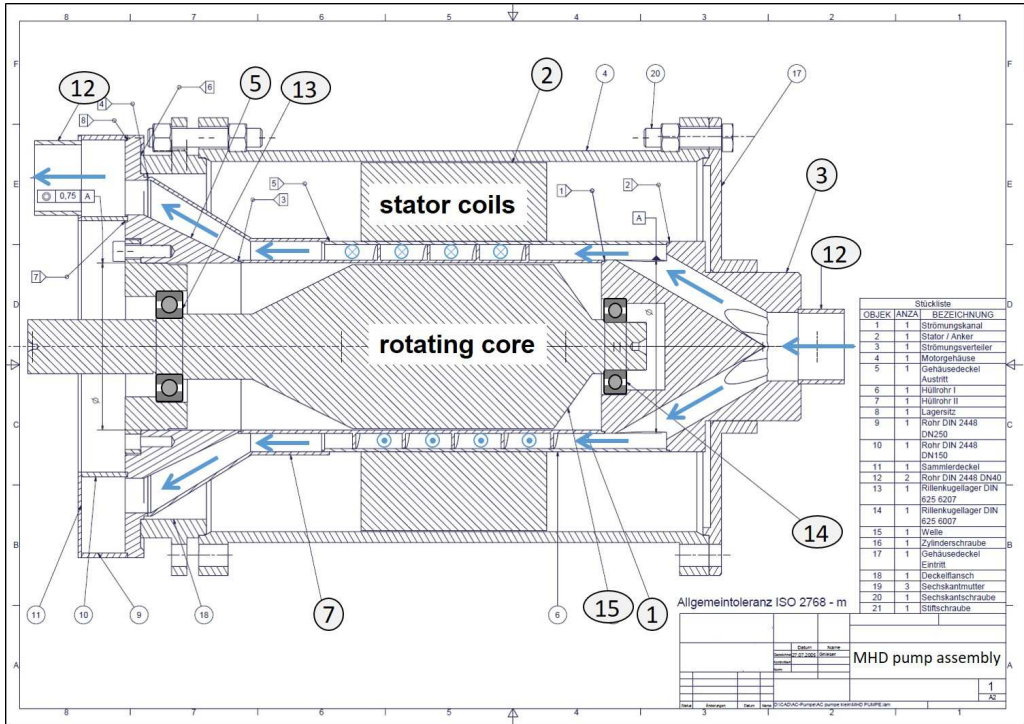

Fig. 1. Design of the helical induction pump, MHD pump assembly.

a new type of liquid metal pump for medium flowrates and moderate pressure heads. The design is shown in Fig. 1. The main components are the helical annular pump channel 1, which is placed in the stator 2 of a former 11 kW induction motor that became available at the institute. The flow is supplied to the annular channel through a DN40 pipe 12 followed by an axial-radial manifold 3. After passing the helical pumping channel 1, the liquid metal continues its path through a conical diffuser 5, 7. Finally, the fluid passes openings at the end of the diffuser body, and it is collected in a larger annular compartment before it leaves the pump through the DN40 exit pipe 12. Magnetic flux lines are closed via a soft iron core 15. While in previous designs of helical induction pumps such as, e.g., [7], the laminated core fabricated from thin transformer plates for reducing induction losses, was entirely submerged in the liquid metal flow, we have chosen here a different approach. In the present design, the iron core, which is fabricated from a single solid piece, is fully accessible from one side (the left side in Fig. 1). For minimization of magnetization losses, the core is mounted on two ball bearings 13 and 14 and permitted momentum-free rotation. During the start-up of the pump, the core accelerates quickly until the rotation rate reaches the frequency of the stator field for which induced currents and Ohmic losses in the iron core then vanish.

In the following, we estimate some properties of the pump. As structural material for the spiral channel walls, stainless steel with a wall thickness of 2 mm was used with the electrical conductivity $\sigma_{\text{steel}} = 1.24 \times 10^6 \frac{1}{(\Omega\text{m})}$ and magnetic permeability μ_0 of free space. A typical penetration depth $\delta = \sqrt{2/\mu_0\sigma\omega}$ for magnetic inductive waves at a frequency of $f = \omega/2\pi = 30 \text{ Hz}$ is about $\delta_{\text{steel}} = 83 \text{ mm}$ in stainless steel so that the shielding effect, i.e. the reduction of the magnetic field in the fluid by eddy currents in the wall,

remains small at about 2.5%. For the liquid metal NaK ($\sigma_{\text{NaK}} = 2.79 \times 10^6 \text{ 1}/(\Omega\text{m})$) we estimate at the same frequency $\delta_{\text{NaK}} = 55 \text{ mm}$ which indicates that the travelling magnetic field affects the fluid in the entire spiral gap which has a radial dimension of 10 mm. The field drops across the pump channel by roughly 17%. If the fluid moved synchronously (no friction losses, no pressure drop) at the mean spiral radius r_s , i.e. with the mean rotation rate $r_s\omega$ of the magnetic field, we could expect at 30 Hz a flowrate through the 10 mm \times 30 mm cross-section of the spiral channel (Fig. 3) as $\dot{V}_s = 3.45 \times 10^{-3} \text{ m}^3/\text{s}$. This leads with the fluid density ($\rho_{\text{NaK}} = 863 \text{ kg}/\text{m}^3$) to an upper limit for a mass flowrate of $\dot{m}_s = 2.98 \text{ kg}/\text{s}$. With viscous effects and Ohmic losses present, and when the pump has to deliver a certain pressure head, the flowrate will become smaller than these ideal values.

The pump was manufactured at the KIT workshop. Photographs displayed in Fig. 4 show the finished pump and its components before assembly. After a pressure test and confirmed tightness, the pump was inserted for testing in the liquid metal NaK loop of the MEKKA facility [8] (see Fig. 2). In order to enable entire draining of the spiral channel by gravity after the tests are completed, the pump was installed with the rotation axis in vertical orientation and inflow from below. A 3-phase power supply with adjustable frequency and current was used during the experiments. The temperature of the liquid metal was monitored by thermocouples in front and behind the pump, primarily for determination of temperature-dependent fluid properties. The flowrate was measured by a Coriolis flowmeter in the NaK loop and the pressure head developed by the pump was detected through a capacitive differential pressure transducer [8]. In addition, the rotation rate of the iron core was measured by an optical sensor. The latter agreed with the frequency expected from the 3-phase power supply.

1. Experimental results.

Experiments were performed by setting the frequency and magnitude of currents in the 3-phase stator coils to predefined values, whereas the flow loop was initially closed by a valve. Then the control valve was opened in small increments leading to a stepwise

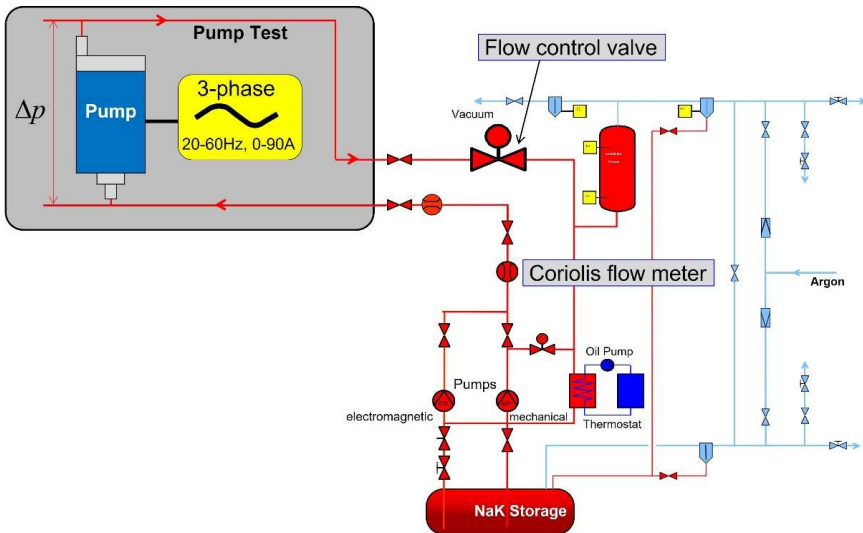

Fig. 2. Sketch of the MEKKA NaK loop with the new pump inserted for testing.

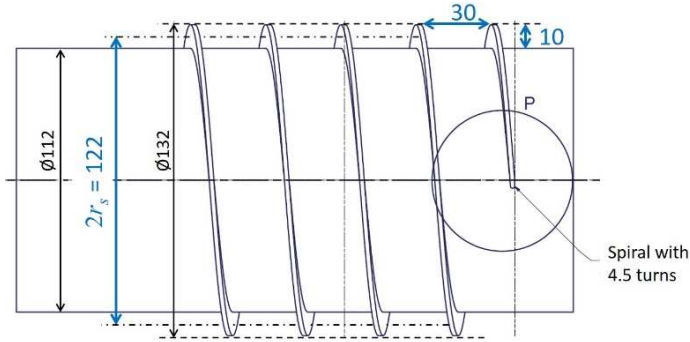

Fig. 3. Details of the helical channel.

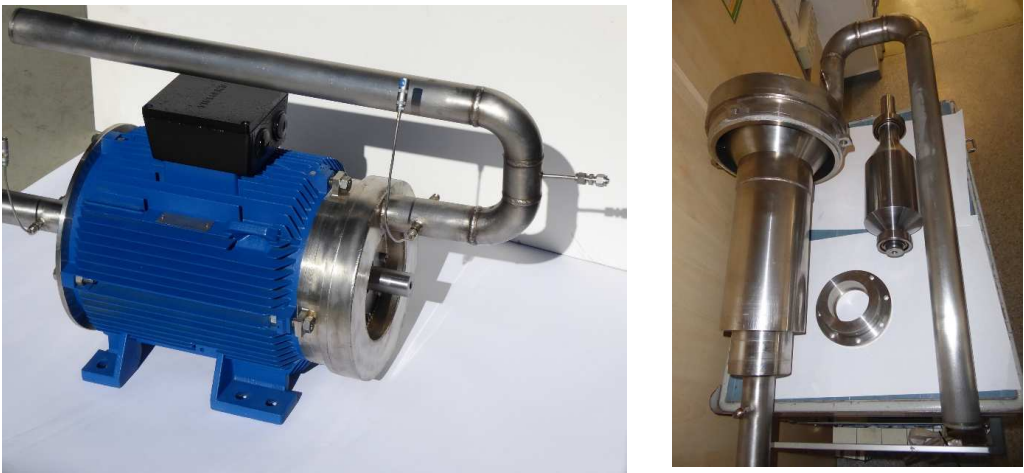

Fig. 4. Photograph of the assembled pump (left) and its components (right).

increase of the flowrate. The pressure head developed by the pump and the flowrate were measured after steady state conditions established. In the following, the pump characteristics are shown with a focus on the pressure head $\Delta p(\dot{m})$ and efficiency $\eta(\dot{m})$ for the specified frequency and current magnitude I . Here, I denotes the sum of currents over all three phases. The pump efficiency η is defined as the ratio of the delivered hydrodynamic power $\Delta p \dot{V}$ in terms of the pressure head Δp and volumetric flowrate \dot{V} and the electric power P_{el} supplied to the engine, i.e. $\eta = \Delta p \dot{V} / P_{el}$.

In the first series of experiments, the total current was fixed to $I = 60$ A while the pump performance was tested for different frequencies in the range from 20 Hz to 60 Hz. Results displayed in Fig. 5 reveal, as expected, that the pressure head Δp decreases with increasing mass flowrate m . With increasing frequency, 20 Hz \rightarrow 30 Hz \rightarrow 40 Hz, the maximum mass flowrate increases further, due to a higher rotation rate of the magnetic field. However, beyond 40 Hz the maximum mass flowrate does apparently not increase further, and the maximum pressure heads become smaller. The maximum efficiency is achieved at a frequency close to 30 Hz.

At the next step, the frequency was fixed at 30 Hz, which is considered close to an optimum value with respect to pressure head and efficiency. In a series of experiments,

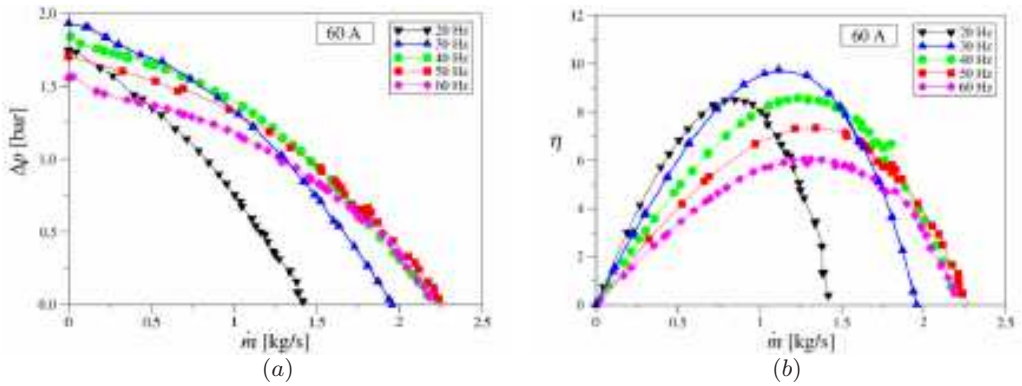

Fig. 5. Pressure head Δp (a) and efficiency η (b) versus mass flowrate \dot{m} for a total current $I = 60$ A and different frequencies.

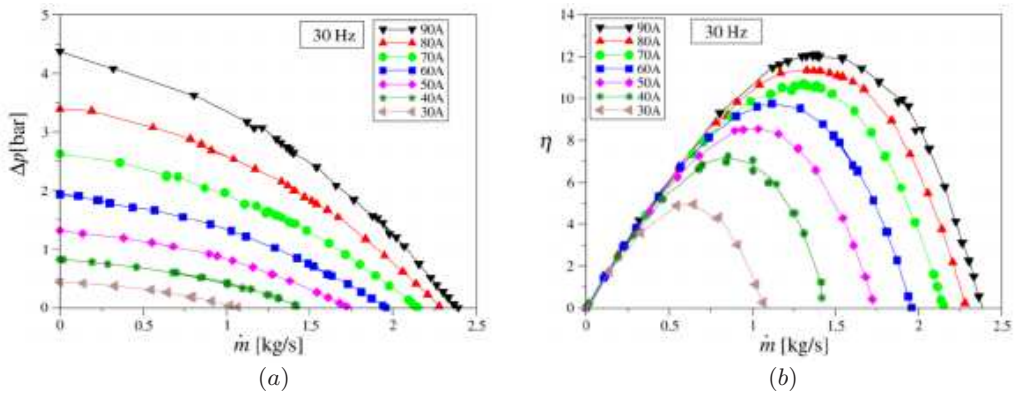

Fig. 6. Pressure head Δp (a) and efficiency η (b) versus mass flowrate \dot{m} for a frequency of 30 Hz and different strengths of currents I .

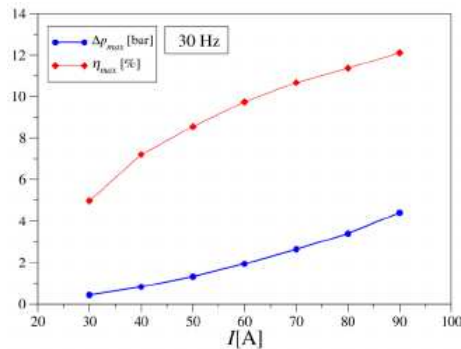

Fig. 7. Variation of maximum values Δp_{max} and η_{max} as functions of I for a frequency of 30 Hz.

it was analyzed how the pump performs with different strengths of the applied current. Results for the pressure head Δp and efficiency η are displayed in Fig. 6. It can be observed that the maximum pressure head Δp_{max} as well as the efficiency η_{max} increase monotonically with increasing currents.

Results for Δp_{max} and η_{max} are summarized in Fig. 7. At the highest investigated current $I = 90$ A, a maximum pressure head $\Delta p = 4.4$ bar and efficiency $\eta = 12.1\%$ are

achieved. From the results it can be anticipated that with currents higher than $I = 90$ A even higher Δp and η values should be possible. Unfortunately, in the present experimental campaign, higher currents could not be applied in stationary conditions due to a lack of active stator cooling and the upper bound on the coil temperature.

2. Conclusions.

A new type of helical induction pump has been designed, built, and tested using NaK as a liquid metal. The pump works best close to 30 Hz and the results are quite promising. The pump delivers a maximum pressure head $\Delta p = 4.4$ bar and a maximum flowrate of about $10 \text{ m}^3/\text{h}$. The highest efficiency of $\eta = 12.1\%$ at a slip $s = (\dot{V}_s - \dot{V})/\dot{V}_s = 0.53$ seems quite good, despite the fact that so far no optimization has been performed for the pump channel geometry. Moreover, with forced (internal) cooling of the stator, it should be possible to allow for larger currents with further increase in Δp and η . Since the central core is fully accessible from outside, it should also be possible to replace it with an active 3-phase-powered non-rotating one for future improvement.

Acknowledgements.

This work has been carried out in the framework of the EUROfusion Consortium funded by the European Union via the Euratom Research and Training Programme (Grant Agreement No 101052200 – EUROfusion). Views and opinions expressed are, however, those of the authors only and do not necessarily reflect those of the European Union or the European Commission. Neither the European Union nor the European Commission can be held responsible for them.

References

- [1] R. STIEGLITZ AND U. MÜLLER. Experimental demonstration of a homogeneous two-scale dynamo. *Physics of Fluids*, vol. 13 (2001), no. 3, pp. 561–564.
- [2] U. MÜLLER, R. STIEGLITZ AND S. HORANYI. A two-scale hydromagnetic dynamo experiment. *Journal of Fluid Mechanics*, vol. 498 (2004), pp. 31–71.
- [3] B. NASHINE. Design, in-sodium testing and performance evaluation of annular linear induction pump for a sodium cooled fast reactor. *Annals of Nuclear Energy*, vol. 73 (2014), pp. 527–536.
- [4] K. POLZIN, J. PEARSON AND K. WEBSTER. *Testing of an annular linear induction pump for the fission surface power technology demonstration unit*. (NASA/TP2013217487, 2013).
- [5] A. BREKIS, L. BULIGINS, I. BUCENIEKS, L. GOLDSTEINS, K. KRAVALIS, A. LACIS, O. MIKANOVSKIS AND N. JEKABSONS. Electromagnetic pump with rotating permanent magnets operation at low inlet pressures. *Fusion Engineering and Design*, vol. 194 (2023), p. 113919.
- [6] I. BUCENIEKS, E. PLATACIS, O. MIKANOVSKIS, A. ZIK, V. MEHTA. Helical type EM induction pump with permanently magnetized rotor for high pressure heads. *Magneto hydrodynamics*, vol. 53 (2017), no. 2, pp. 423–428.
- [7] E.M. AVILOVA, T.V. DOKTOROVA, N.I. MARIN, V.A. POVSTEN, N.M. TURCHIN. Development and operation of helical-flow induction pumps. *Magneto hydrodynamics*, vol. 1 (1965), no. 1, pp. 81–83.

Design, fabrication and experimental test of a helical induction pump with rotating core

- [8] L. BARLEON, K.-J. MACK AND R. STIEGLITZ. *The MEKKA-facility a flexible tool to investigate MHD-flow phenomena.* (Forschungszentrum Karlsruhe, FZKA 5821, 1996).

Received 29.11.2024